

860 PACKER CONVEYOR

Packer Conveyors are designed to suit the severe conditions that are required for a serviceable installation with STONEPAK Valve Bag Packers. This Packer Conveyor can be custom engineered to your plant layout by STONEPAK engineers with years of experience in bag handling. The reverse side details some of the available options.

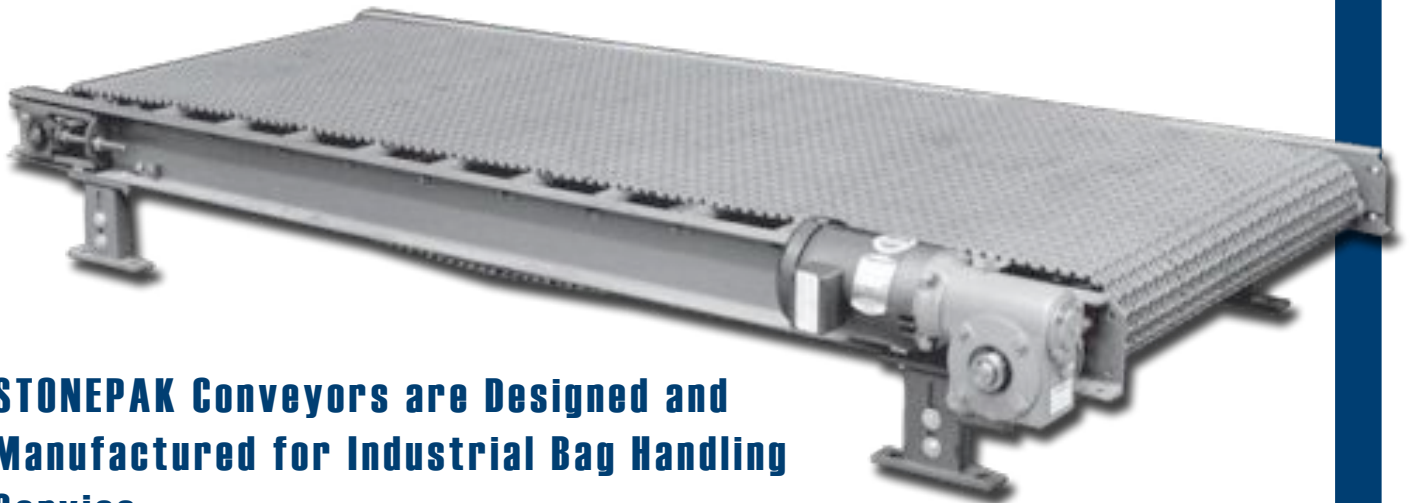

STONEPAK Conveyors are Designed and Manufactured for Industrial Bag Handling Service

Frame: Welded construction of 6" channel

Belt: 1/2" x 1" mesh heavy duty galvanized flat wire

Sprockets: For wire mesh belt

Speed: Standard speeds 27, 36, 57, 73, 100 and 117 ft. per min

Take Up: Stainless steel for trouble free belt adjustment

Guarded: At pinch points and drive

Motor: 230/460 V, 3 ph, 60 Hz TEFC, 1 HP

Bed: Dense roller bed to reduce belt friction for longer belt life

Rollers: Low maintenance, lubricated for life bearings

Optional Equipment



Operator Seat and Foot Rests

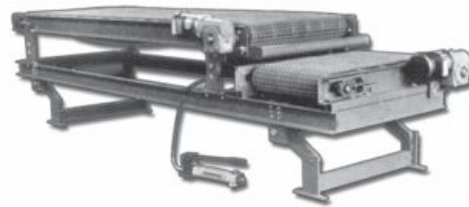

Powered Raising and Lowering Assembly

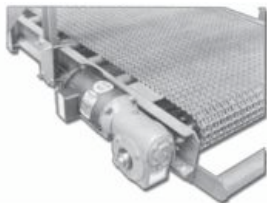

Tip Bar



Roller Discharge with Stop Plates

Parts & Service Capability

STONEPAK maintains a large inventory of parts to insure that your equipment is maintained at the highest operating efficiency. Service personnel are available at established rates.

Other Optional Equipment

- Explosion proof motors
- Bag roll back bar
- Tip-over fence
- Casters
- Bag roll plate assembly



**Premier Tech
Systems**

1881 West North Temple
Salt Lake City, UT
84116 U.S.A.

☎ 801 595-6800
☎ 801 363-7830
@ stonepak@premiertech.com
WWW.STONEPAK.COM

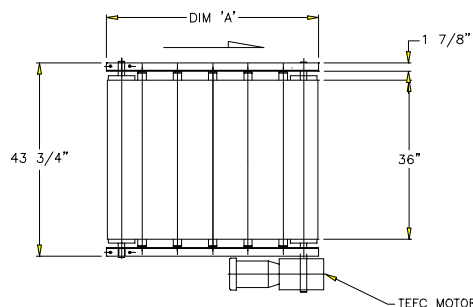

NOTES:

1. Dimension A - Length available from: 34-0i thru 20i-0i (in 1 foot increments).
2. Dimension B - Height available as follows: adjustable 12i to 13 1/2i; 13 1/2i to 15 1/2i; 18i to 24i to 36i; 36i to 60i.
3. Belt: 1/2i x 1i Mesh Heavy Duty Galvanized Flat Wire.
4. Electrical Power: 230/460 VAC, 3 PH, 60 Hz.
5. Belt speeds available: 27 FPM, 36 FPM, 57 FPM, 73 FPM, 100 FPM, 117 FPM.

