

840 Closing Conveyor

STONEPAK Closing Conveyors are designed to suit the severe conditions that are required for a serviceable installation with STONEPAK Closer/Sealer-Closer or any other type of closing equipment. This Closing Conveyor can be custom engineered to your plant layout by engineers with years of experience in bag handling. The reverse side details some of the available options.



Frame: Welded construction of 6" channel

Pulleys: 6" diameter crowned and lagged head pulley

Speed: Adjustable from 19 to 54 ft./min. to synchronize with closer speed

Bed: Dense roller bed to reduce belt friction for longer belt life

Take Up: Stainless steel for trouble free belt adjustment

Guarded: At pinch points and drive

Motor: 1 HP TEFC 230/460 V, 3 ph, 60 Hz

Belt: Interwoven polyester belt with PVC cover. Long wearing low stretch superior rip, tear and gouge resistance

Rollers: Low maintenance, lubricated for life bearings



90° All-Pneumatic Bag Transfer

Optional Equipment

- Caster mounting with position locks
- 90° All-Pneumatic Bag Transfer - left hand or right hand discharge
- Explosion proof or severe duty motor
- Center take up for fixed length installations
- Positive tracking belt

Parts & Service Capability

STONEPAK maintains a large inventory of parts to ensure that your equipment is maintained at the highest operating efficiency. Service personnel are always available at established rates.

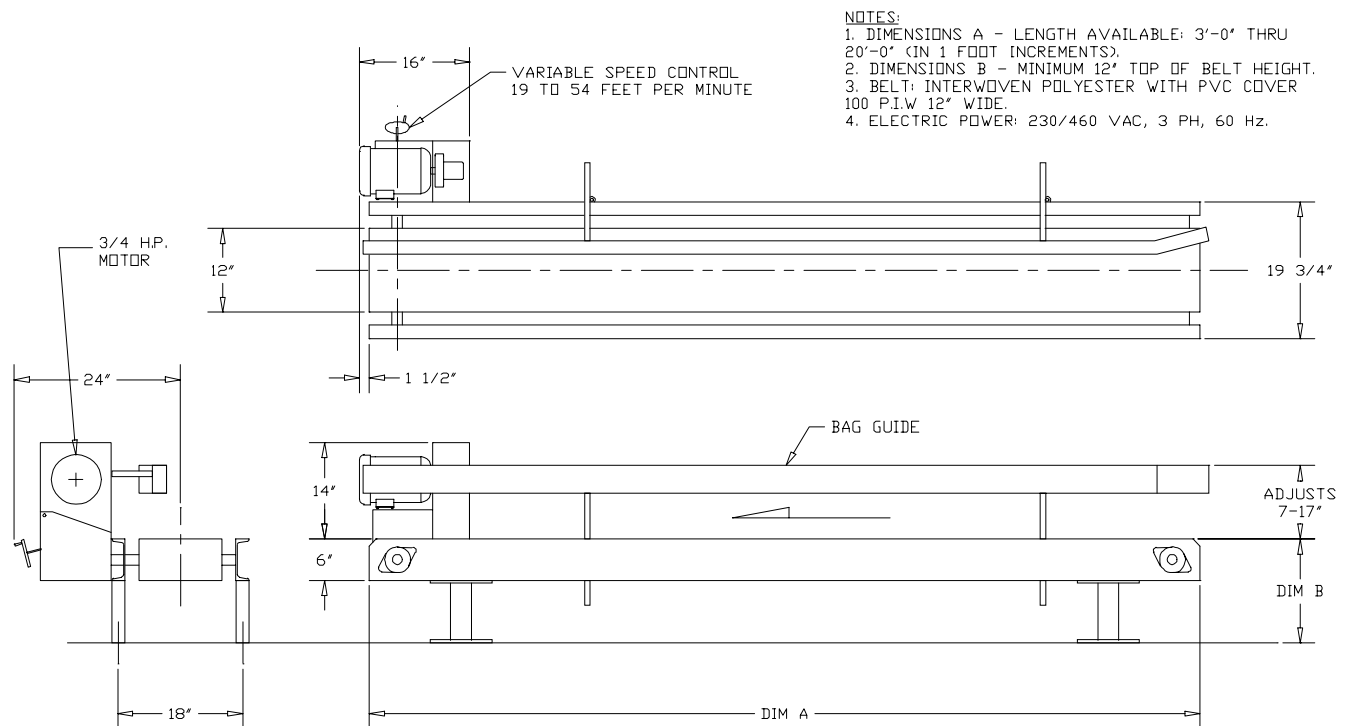

1881 West North Temple
Salt Lake City, UT
84116 U.S.A.

☎ 801 595-6800
 ☎ 801 363-7830
 @ stonepak@premiertech.com
WWW.STONEPAK.COM