

720 MP

ELECTRONIC FORCE FLOW PACKER Valve Bag Filling Machine

The newest addition to the STONEPAK valve bag air packer line offers both increased weight accuracy and simplified operation.

The Model 720 MP Force Flow electronic packer is engineered to fill and weigh fine powders, flaked products, pellet and granular materials while yielding a weighing accuracy of ± 3 oz. @ 2 sigma on most products.



Features

- Full flexure machine (no scale beam)
- All electric solenoid valve controls
- Electronic timers
- Checkweigh / Feedback
- LCD display with text messaging
- Keypad initiated calibration
- English / Spanish display
- Multiple product setup parameter storage (up to 10 products)
- Pre-hosed 4" dust collection port

Technical Specifications

Bag Capacity:

- 22-110 lbs (10-50 kg)

Filling Rate:

- 2-8 50 lb (25 kg) bags a minute

Compressed Air:

- 1.5 cu ft @ 80 psig per bag packed required

Low Pressure Air:

- 150 scfm @ 6 psig required (typically supplied by a low pressure blower)

Gross Shipping Weight:

- 900-1300 lbs (400-600 kg)

Filling Tubes:

- 1 5/8" - 4 1/4" OD (4.1 - 10.8 cm) for 3" - 8" (7.6 - 20.3 cm) valves

Dust Collection Requirements:

- 400 scfm recommended

Options

- Force flow, atmospheric or plug stack models are available
- Bag blow-off wand for use with applicator
- Automatic start switch
- Start / stop enclosure for manually operated model
- Configuration for NEMA 4/12 or II-G-1 / II-G-2 installations

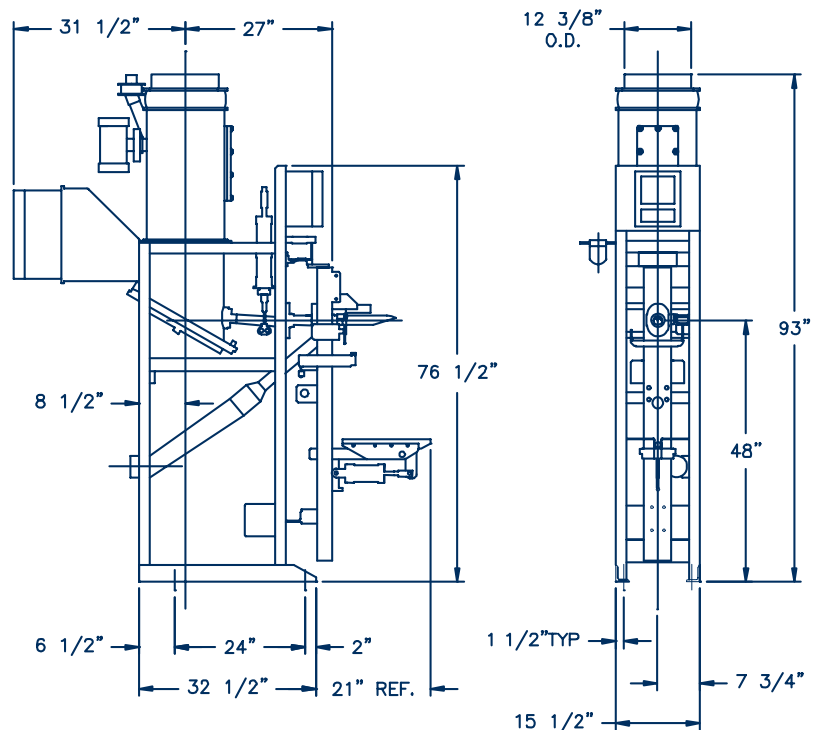

1881 West North Temple
 Salt Lake City, UT
 84116 U.S.A.

☎ 801 595-6800
 ☎ 801 363-7830
 @ stonepak@premiertech.com
WWW.STONEPAK.COM