

602-E AUTOMATIC APPLICATOR For Pinch Bottom Bags



Positive Closures to provide optimum product protection.

Tight positively closed pinch bottom bags are assured by rigid control of the bag top at each step of the operation. The filled bag enters the closer or sealer/ closer at the correct height and properly leveled for secure closure. No chance of misfolded or distorted gussets - gussets are never unfolded.

Productive to reduce unit cost.

Fully automatic operation provides paced operation. Up to 10 bags per minute on a steady basis. Reload bag magazine without interrupting production. Rugged design assures maximum "up-time".

Economical Package to reduce your bagging costs.

Effective settler allows use of smallest and most economical bag size for your product.

Simple to maintain and operate.

Mechanically simple and rugged design. Simple touchscreen operator controls. Solid state electronic control reliability.

Clean to maintain a clean working environment and reduce product loss.

Effective dust collector duct permits user's dust collector to remove product dust. Dual sensors prevent spillage if bag is not properly placed on spout.

Bag gussets are held firmly throughout the filling and handling process. This assures a proper bag closure.

Basic Model 602-E includes:

- Empty bag magazine
- Bag feeder
- Stainless steel product contact surfaces
- Bag settler with motor
- Bag top transfer belts with motor
- Venturi style vacuum generators
- Motor controls
- Allen Bradley programmable controller (SLC 5/03)
- Dust collection duct
- NEMA 12 dust tight electrical closures
- Touchscreen operator controls

Auxiliary items:

- Net weigh scale
- Closing conveyor and bag closer
- PLC upgrades

Technical Specifications:

Bag weight:

- up to 50 KG (112 lb.)

Bag type:

- pinch bottom open mouth - paper

Shipping weight:

- 4,500 lb. (approximately)

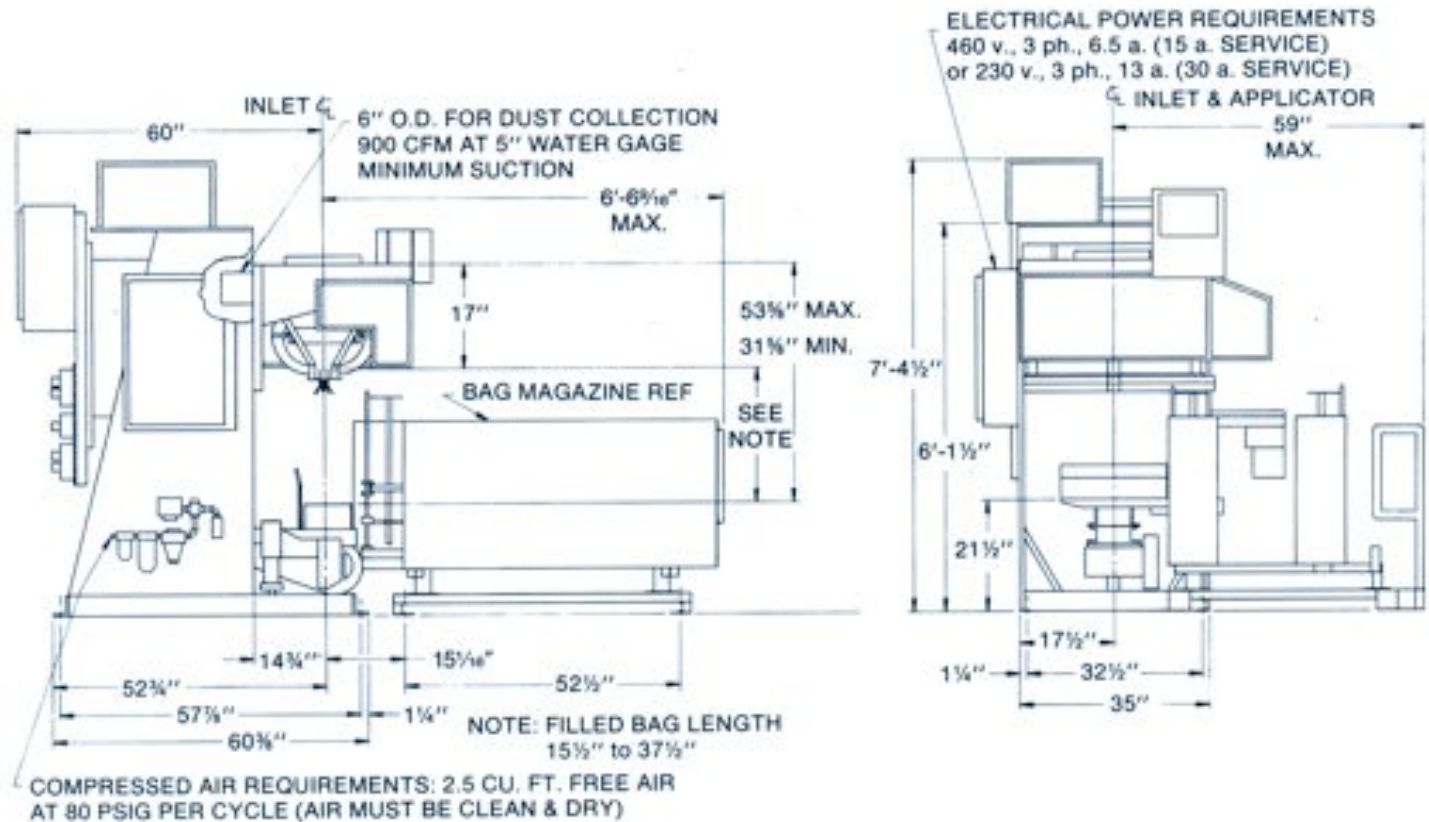

Premier Tech
Systems

1881 West North Temple
 Salt Lake City, UT
 84116 U.S.A.

☎ 801 595-6800
 ☎ 801 363-7830
 @ stonepak@premiertech.com
WWW.STONEPAK.COM