

US2001 & US2002 IN-LINE ULTRASONIC SEALERS

Patented positive valve bag sealing uses ultrasonic energy, not heat, for a cleaner weld and no product degradation. Operates at rates up to 12 bags per minute (bpm) on Model 2001 and 22 bpm on Model 2002.

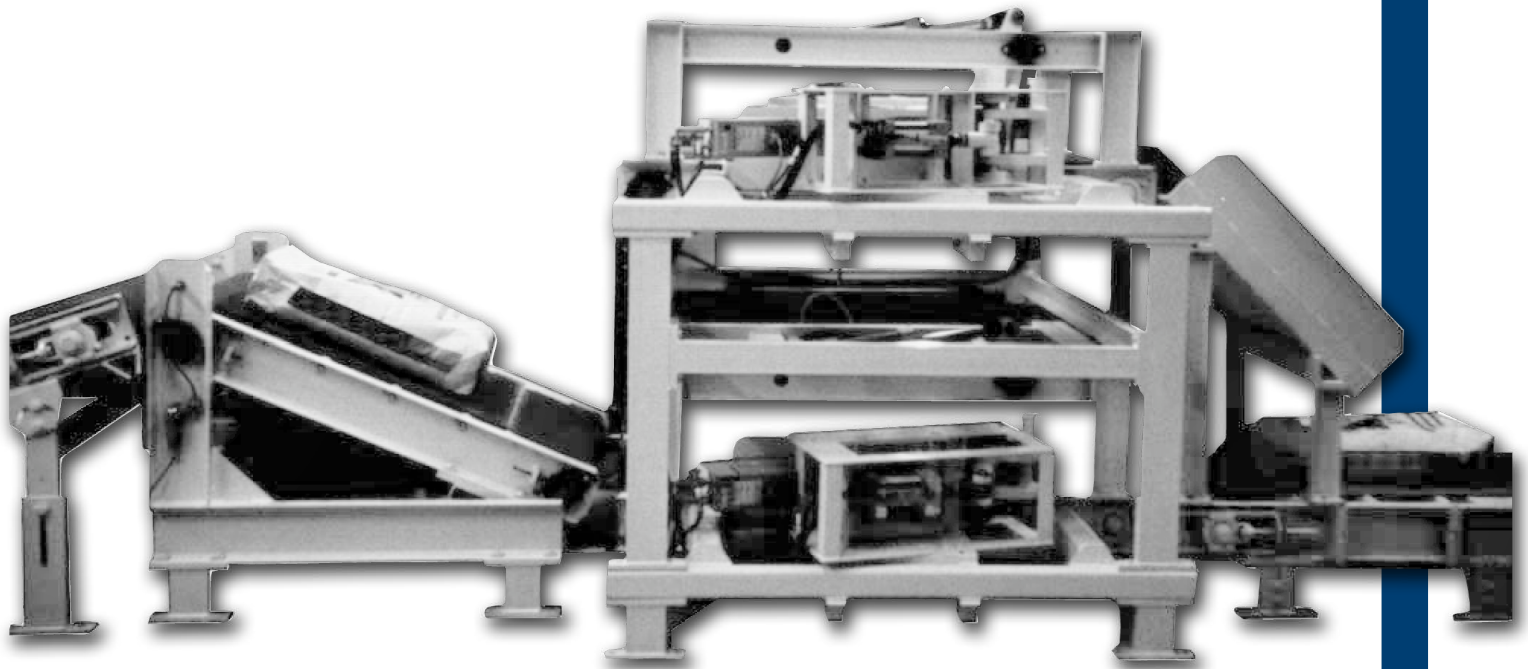

US2001 and US2002 Ultrasonic Sealers are designed to seal a wide variety of products in valve bags, and work with STONEPAK air, auger and impeller packers.

The US2001 and US2002 in-line valve sealers use ultrasonic energy to displace product from the seal area of external valve bags and weld the sealable sleeve. The sealed bag is immediately released to a downstream conveyor.

The Model US2001 is a basic, single machine that seals up to 12 bags per minute. The Model US2002 is a higher speed, double-deck version with two sealers stacked one on top of the other. A bag diverter sends the bags alternately to the upper and lower sealers. Sealing rates of up to 22 bags per minute are attainable with the Model US2002.

Features:

- Positive sealing - even through heavily contaminated valves
- Patented ultrasonic sealing method - no heat used
- High speed unit for multiple packers
- Low cost valve sealing
- Minimum floor space requirement.

Optional Equipment

- Choice of Lexan (plexiglass) or perforated steel guard material
- Easy Adjust Side Former - enables valve bag size adjustments to be made without hand tools
- Power Lock Down Easy Adjust Side Push - allows adjustment to be made without opening the guard door

Technical Specifications

- Electrical: 230 VAC, 3 ph, 50/60 Hz, (transformer available for 460 VAC)
 - US2001 - 30 amps@230VAC (15 amps@460 V)
 - US2002 - 50 amps@230VAC (25 amps@460 V)
- Air consumption: US2001: 15 scfm @ 80 psig; US2002: 35 scfm @ 80 psig
- Dust collection: US2001: 400 scfm; US2002: 800 scfm
- Conveyor speed: 155 ft/min
- Approximate weight: US2001: 1200 lbs; US2002: 2500 lbs

U.S. Patent Nos. 5,244,532; 5,620,542

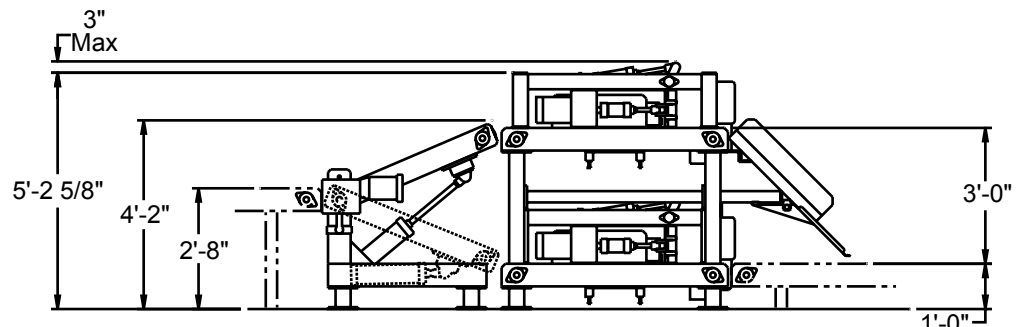
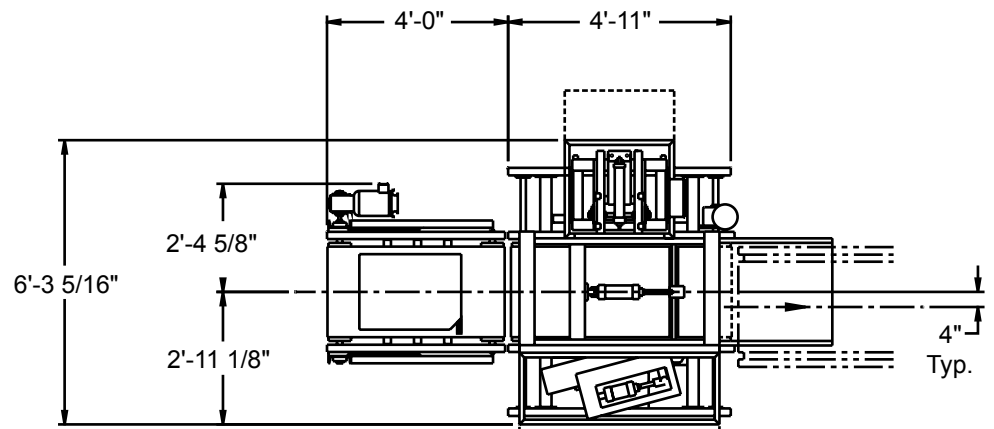
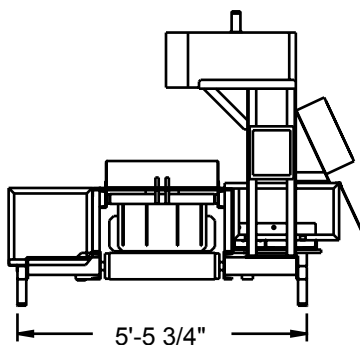

**Premier Tech
Systems**

1881 West North Temple
Salt Lake City, UT
84116 U.S.A.

☎ 801 595-6800
☎ 801 363-7830
@ stonepak@premiertech.com

WWW.STONEPAK.COM